

Vertical Lift Station Applications

Illustrate as simplex system with - float level sensors and top cable junction boxes

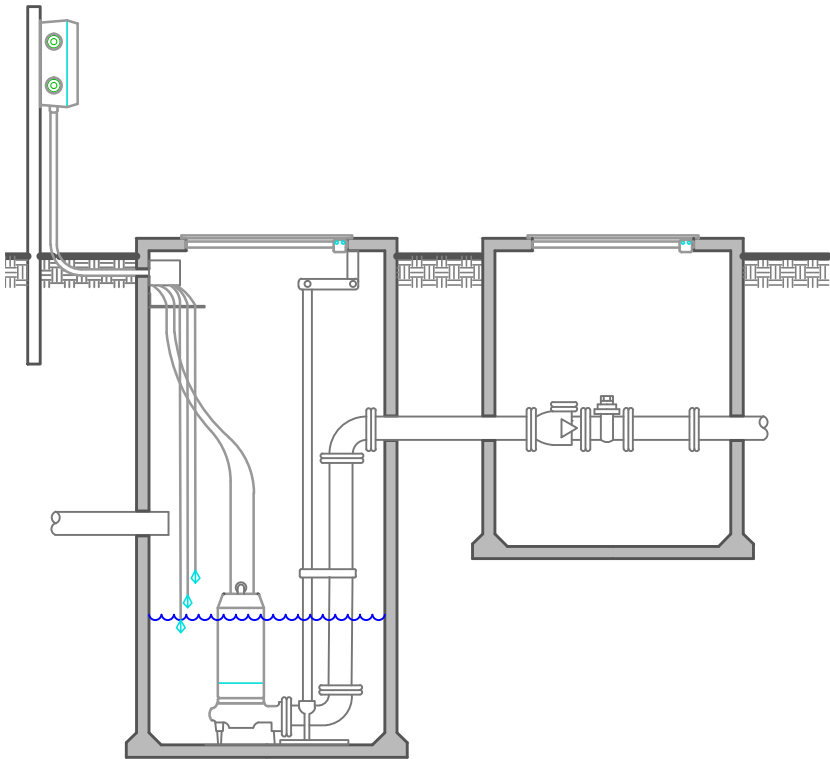

Guide Rail

Typically used in waste water applications w/ large solids
separate valve box recommended

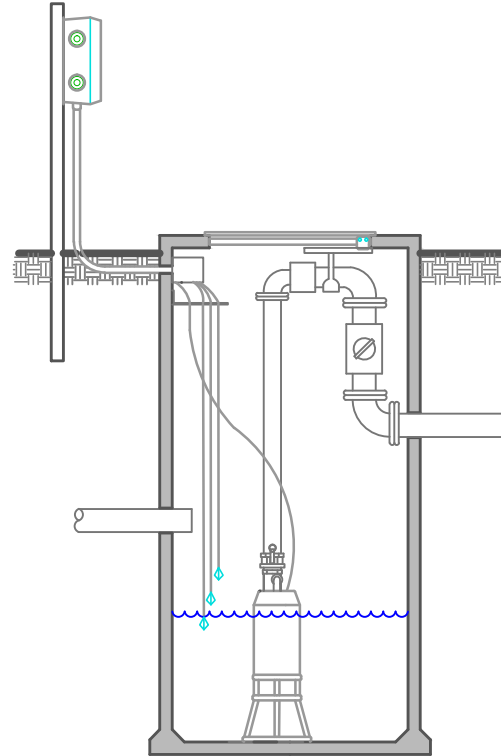

Pump w/ Stand

Typically used in condensate and leachate transfer applications. Stand places pump inlet above sediment. Disconnect methods allow easy access without entering wet well

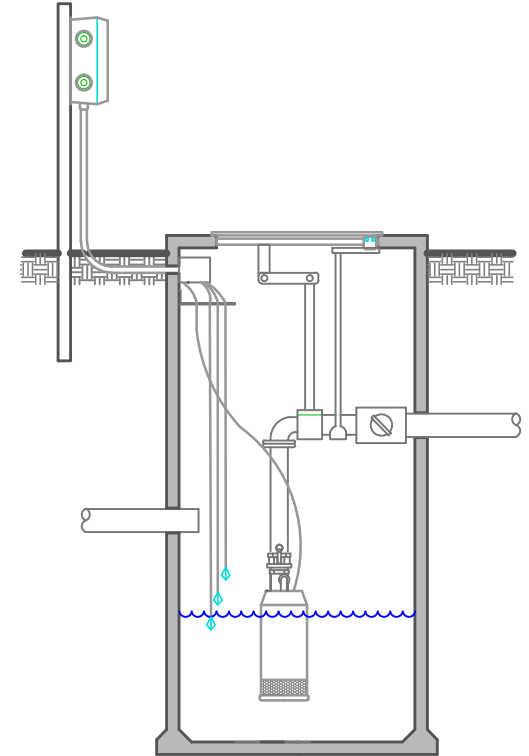

Suspended Pump w/ Pitless Adapter

Typically used in condensate and leachate transfer applications. Pitless adapter supports pump and allows access without entering well.

GunnCo

Pump & Control, Inc.

515 Industrial Way Cumming, GA 30040
(770) 889-7114 info@gunnco.com

Sidesloper™ Pumps